

Instruction manual  
Catalyst



**BLUEFIRE**

Inhalt	Page
Allgemeine Hinweise	3
Funktionsbeschreibung	3
Installation position of the catalyst	3
Assembly of the catalytic converter	4
Bypass	5
Reinigung	6
Permitted fuels	8
Betriebsdauer	9
Disposal / Recycling	10
Improper Verwendung	10
Retrofitting of a catalyst	10
Brandschutzverordnungen	10
Guarantee conditions and Gewährleistung	11
Technical Daten	11

## General notes

Thank you for choosing a catalyst from Blue Fire GmbH. Catalysts from Blue Fire GmbH are characterized by their long service life and high degree of emission reduction at economical costs. In these operating instructions we explain the assembly, handling and cleaning of the available catalysts.

Picture shows Blue Fire sponge ceramic catalyst (Picture: Blue Fire GmbH)

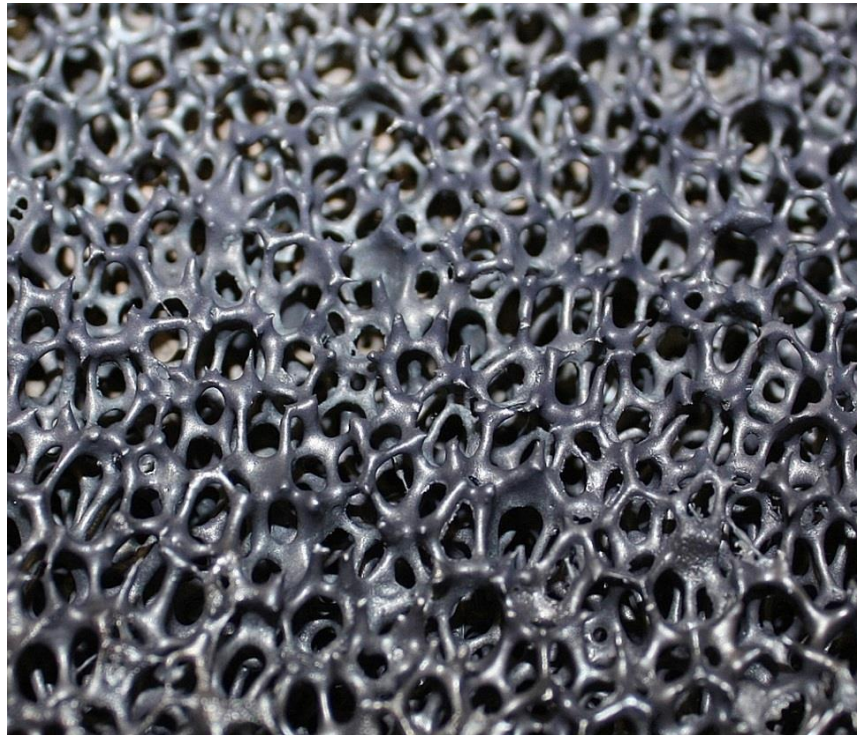

## Functional description

The catalysts from Blue Fire GmbH work with different carrier systems and also with different coatings. Common to all catalysts is the high activity in the application area chosen by the customer. All catalysts are adapted to the customer's application in terms of carrier system and catalytically effective coating in order to achieve optimum emission reductions.

## Installation position of the catalyst

The catalyst should be integrated into the upper part of the combustion chamber of a furnace. It should always be noted that permanent, direct flame contact with the catalyst can lead to deactivation of the catalyst. A short flame contact in the ignition phase does not damage the catalyst. To protect the catalyst from permanent flame contact and to reduce the flow velocity, the catalyst is located in front of the catalyst in the direction of flow,

always and without exception, to provide a flame baffle. Our engineers will be pleased to help you determine the suitable position of the catalyst, the flame baffle and the bypass in the furnace. The catalyst must be integrated into the furnace in such a way that it is well flowed through. The bypass prescribed by the standards for the various firing systems must be implemented in the installation area of the catalyst. The bypass shall be dimensioned in accordance with the relevant standards.

## Assembly of the catalyst

### Unpacking and handling

The catalysts are coated with a catalytically active layer. This coating can consist of mixed metal oxides or precious metals. In order not to limit the effect of this catalytically active layer, the catalysts may only be handled with gloves, preferably disposable gloves.

Picture shows protective glove (Picture: Blue Fire GmbH)



Remove the catalysts from the transport packaging and carefully insert them into the holder provided by the manufacturer.



**Important:** The catalysts are fragile and must be handled very carefully. be caught. Avoid a bump and let the catalyst does not fall. This could destroy the catalyst!

### Inserting the catalysts

The catalysts must be used in ein Haltesystem eingesetzt werden, damit diese sicher im Brennraum fixiert werden. Die Halterungen sind most

made of highly heat-resistant stainless steel, since the hot exhaust gases directly affect these components. The brackets and installation situations vary depending on the type of furnace.

The catalyst should be wrapped around the material thickness with a sealing cord so that it does not come into contact with metallic supports at these points and to prevent exhaust gas leakage or loose fit is necessary to compensate for the different thermal expansions of the two materials steel and ceramic.



**Important: Make sure that the catalytic converter is in the holder is not damaged.**

**Make sure that the seal does not cover the catalyst surface to be flowed through.**

Then insert the holder, including the catalysts used there, into the space provided in the furnace.

Picture shows holding system with flame baffle plate and bypass (Picture: Blue Fire GmbH)

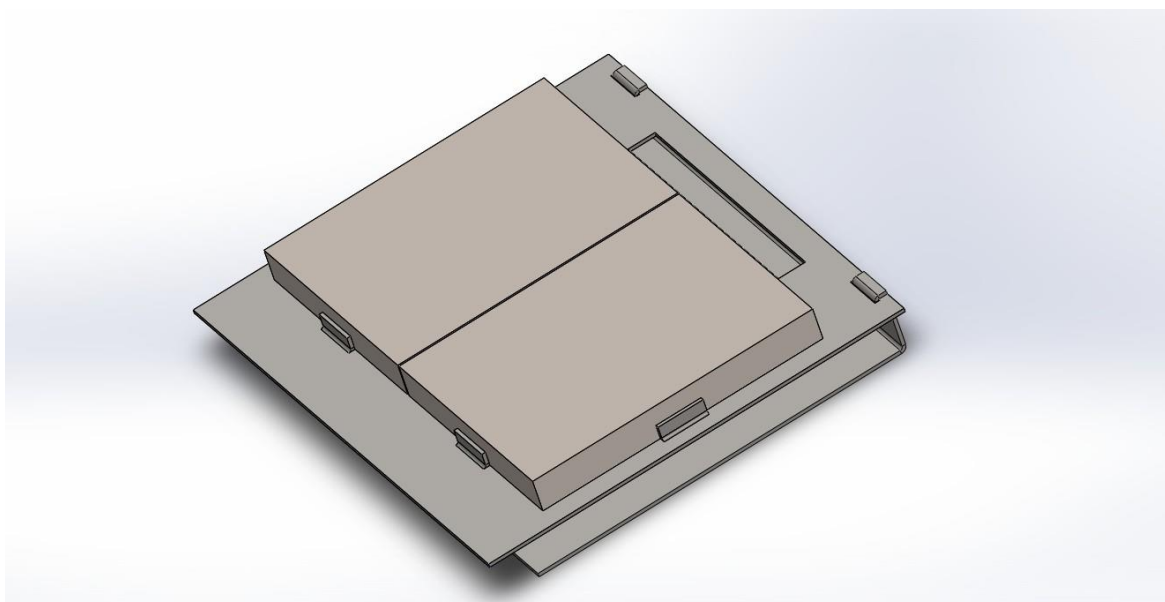

## Bypass

Catalysts may only be used in wood-burning stoves (EN13420), fireplace inserts (EN13229) and sauna heaters (EN15821) with bypass. Before installation and

Commissioning it has to be ensured that a bypass is realized which meets the requirements of the mentioned standards.

Here is an extract from the EN 13229 standard:

<b>No. No.</b>	<b>Topic/ Transcription</b>	<b>Decision Decision</b>
13-01	filtersin appliances  <i>Filterin devices</i>	Clause 4.5.2 of EN 13229 (or the appropriate clauses in other relevant standards) applies also (30 mm / 15 mm for wood burning appliances of minimum dimension in the flueways). For appliances using filter designs not in line with this requirement the filters are handled like dampers and the appliances shall have a bypass of at least 3 % square area or at least 20 cm <sup>2</sup> (in accordance with 4.14 of EN 13229 dampers). If none of the above safety relevant solution is chosen the appliance do not pass the hEN's. <i>Section 4.5.2 of EN 13229 (or the corresponding sections of other standards) also applies (30 / 15 mm for the minimum widths of the heating gas flues of wood fired appliances). Devices using filter constructions which do not meet this requirement are to be considered as dropping devices. The units must therefore have either a minimum of 3 % of the cross-sectional area or a continuous area of at least 20 cm<sup>2</sup> (as per point 4.14 of EN 13229). If none of the above safety relevant solutions is selected, the devices do not comply with the hEN's.</i>

## Cleaning

Depending on the operating time, the fuel and the usage behaviour of the operator, the catalyst has to be cleaned, as coarse dust particles are deposited on the inflow surface due to the flow of exhaust gas. These coarse dust particles must be removed from the catalyst surface at least regularly. The operator must observe the degree of contamination and decide when cleaning is indicated. As an assistance we show here a clean Blue Fire catalyst and a dirty Blue Fire catalyst.

### Clean catalyst (Picture: Blue Fire GmbH)



### Dirty catalyst (Picture: Blue Fire GmbH)



### Cleaning equipment

For cleaning you can use a hand brush, a brush or a vacuum cleaner. If you use a vacuum cleaner, please use a brush only.

Picture shows cleaning devices (Picture: Blue Fire GmbH)



### Ash vacuum cleaner

In addition, we recommend using an ash vacuum cleaner, which is available at your local DIY store, for example.

## Compressed air

If the installation situation is difficult to access, we recommend cleaning the catalyst by blowing with compressed air at regular intervals. In doing so, however, avoid the release of dust particles into the installation room in any case. Also make sure that the compressed air does not have a pressure higher than 6 bar, otherwise the catalyst could be damaged. In this case, you should always consult your furnace manufacturer or dealer.

Picture shows compressed air pistol (Picture: Blue Fire GmbH)



**Important: Make sure that the catalyst is not damaged during cleaning will.**

## Permitted fuels

Only the following may be used for heating: Logs and compressed wood according to DIN 51731. Logs may only be used air-dry with 15 to 24% wood moisture (13 to 19% water content). Burning any kind of waste is forbidden according to the Federal Immission Control Act. This can also lead to damage to the fireplace and chimney.

We expressly point out that it is forbidden to burn wood with nails or with metal residues. In this case the guarantee we have promised expires.

The use of softwoods as logs should be avoided due to their low calorific value and high ash content. The use of softwoods can lead to increased wear and premature blocking of the catalyst.



**Important:** Resin-containing softwoods lead to rapid blocking of the catalyzed wood.

sators. Avoid the use of soft oil sators if possible.

like spruce or pine etc.

**Blocked catalysts must not be operated any longer. The blocked catalyst must be cleaned before further operation. See page 6, section Cleaning.**

**Catalysts blocked with tar cannot be cleaned and must be replaced immediately!**

#### Info:

Air-dry logs with a maximum of 24 percent water is achieved by drying for at least one year [ softwood ] or two years for hardwood.

**Important:** Wood is not a continuous burning fuel, that means: a heating through overnight is not possible with wood.

## Operating time

The service life and operating time of the catalyst depend on many factors, which are primarily influenced by the user of the furnace. These are the following factors:

- Type and quality and residual moisture of the fuel
- Frequency of using the furnace during the day and during the heating period
- The way of operation of the furnace, especially correct air supply and temperature level
- Quantity and frequency of fuel application
- Method and frequency of cleaning and maintenance of the furnace and catalyst
- Protection against mechanical damage

If the above mentioned parameters correspond to the specifications of the combustion manufacturer as well as to these instructions, a catalyst should be able to withstand at least 3 heating periods without needing to be replaced. The responsible district master chimney sweep can determine the faultless function of the catalyst even after the operating period of 3 years by means of an emission measurement. For this purpose, the operator must commission the district master chimney sweep with an emission measurement.

## Disposal / Recycling

At the end of its useful life, after damage or improper use, the Blue Fire catalyst must be replaced. The used catalyst does not have to be disposed of, but can be recycled. The precious metals contained in the catalyst can be reused to a very high degree.

End users should return the used catalytic converter to the manufacturer of the furnace via their specialist dealer. Blue Fire GmbH will take back the used catalysts from the manufacturers of the firing system, provided that they are delivered to our company address free of charge for Blue Fire GmbH.

## Improper use

The Blue Fire catalyst must not be fired with: Waste, plastics, paint residues, paper, sawdust, oils, oil residues.

It must be ensured that sufficient combustion air is supplied. The Blue Fire catalyst is an oxidation catalyst and always requires an excess of oxygen in the combustion process to function properly.

No changes may be made to the catalyst, otherwise the approval for the firing system type-tested with the catalyst and the warranty for the catalyst expire.

Only original spare parts may be used. These can be obtained from the manufacturer. Non-observance will result in the loss of the approval and the warranty.

Overloading of the Blue Fire catalyst beyond the determined and recorded values will result in destruction of the catalyst.

## Retrofitting of a catalytic converter

In case of a catalyst retrofit in a furnace that has already been in operation, the operator is obliged to prove compliance with the valid emission limits according to the applicable laws and regulations. This is done by obtaining a written release of the fireplace with retrofitted catalyst from the responsible district chimney sweep.

## Fire protection regulations

The respective national fire protection regulations must be observed and complied with!

## Guarantee conditions and warranty

You have chosen a catalyst from Blue Fire GmbH and thus acquired a product that is processed under the highest quality standards.

Unfortunately, we cannot give any guarantee on the durability of the catalysts and we also exclude the warranty for it, as the condition and function of the catalyst depends 100% on the behaviour of the user. If the user does not follow these instructions, this will result in damage or failure of the catalysts. Wir sichern jedoch zu, dass der Katalysator im Zustand der Auslieferung die bestimmungsgemäße Funktion erfüllt. The quality of the catalytic coating is monitored and electronically documented during the production process. We therefore guarantee the promised coating quality and provide evidence of this on request.

Damage caused by transport must be proven to us, for this purpose the damaged goods must be returned to us for examination.

Furthermore, no liability is assumed for consequential damages caused by defects, in case of intent, gross negligence, violation of essential contractual obligations by the manufacturer and supplier, injury to life and limb.

The severability clause applies to these guarantee conditions and we refer to our general terms and conditions.

## Technical data

### Metal Oxide Catalyst

Starting temperature catalyst type 023-00:	350° C
maximum working temperature catalyst type 023-00:	800° C
Chimney negative pressure:	12 Pa
Pressure loss through catalyst:	0,5 Pa
Optical control of the catalyst <sup>1,2,3</sup>	1x / week recommended
Cleaning interval <sup>1,2</sup>	according to the specifications of the furnace manufacturer
Service life of catalyst type 023-00 <sup>1,2</sup>	3 heating periods <sup>1,2</sup>

## **Precious Metal Catalyst**

Starting temperature catalyst type 030-10 /-40:	250° C
maximum working temperature catalyst type 030-10 /-40:	800° C
Chimney negative pressure:	12 Pa
Pressure loss through catalyst:	0,5 Pa
Optical control of the catalyst <sup>1,2,3</sup>	1x / week recommended
Cleaning interval <sup>1,2</sup>	according to the specifications of the furnace manufacturer
Service life of catalyst type 030-10 /-40 <sup>1,2</sup>	3 heating periods <sup>1,2</sup>

<sup>1</sup> Depending on frequency of use, type, quality and composition of the fuel, quantity of the fuel as well as type and composition of the relevant furnace and the associated chimney system.

<sup>2</sup> Only valid if the information given in this operating manual has been observed without restriction.

<sup>3</sup> A visual check must be made to determine whether the catalyst is blocked (tar formation on the upstream side) or whether it is covered with dust (see photo on page 7 of these instructions) and needs to be cleaned, or whether it is clean and can be used again (see photo on page 7 of these instructions)

Subject to optical and technical changes.

Revision Index: 03/200429



**BLUEFIRE**

**Blue Fire GmbH**

Industriestr. 5

26683 Saterland-Ramsloh

Phone +49 4498 92326-130

[contact@blue-fire.org](mailto:contact@blue-fire.org)

[www.blue-fire.org](http://www.blue-fire.org)